

Pneumatické proporcionálne riadenie 3 - Riešenia a zapojenia :)

1 Ovládanie frekvencie vysúvania a zasúvania piesnice pneumatického valca

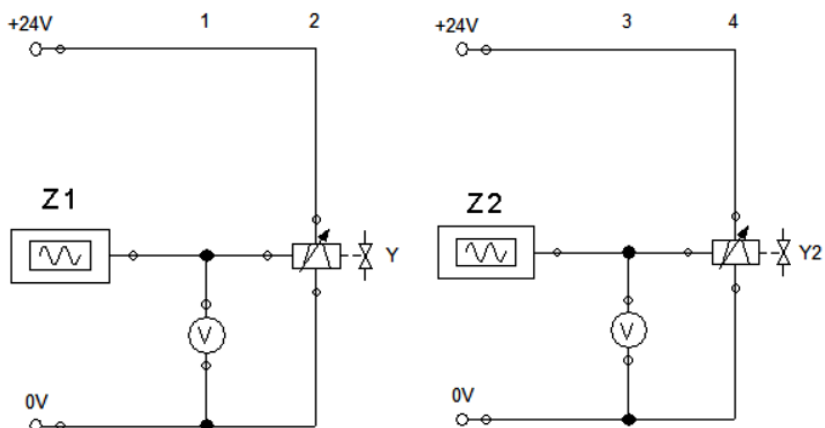
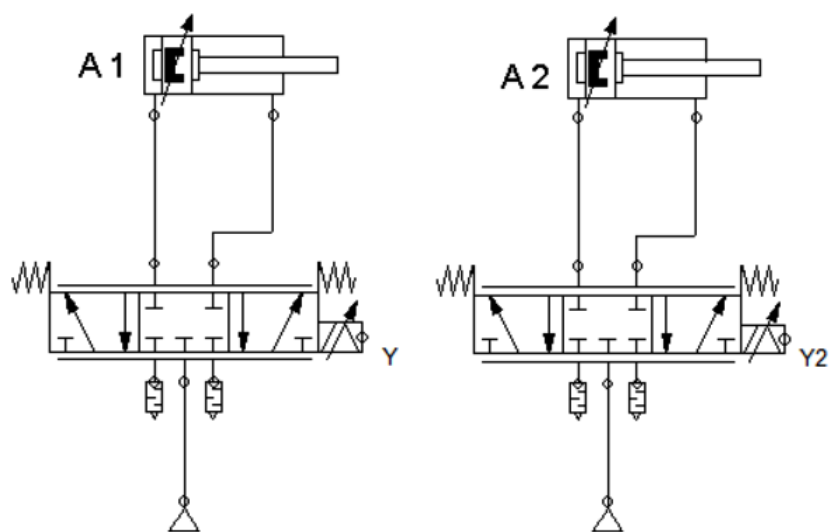

Function generator

Signal type

Constant
 Rectangle
 Sine
 Triangle
 Voltage profile

Edit profile...

Signal parameters

Frequency Hz (0..100)

Amplitude V (0..10)

y offset V (-10..10)

OK Cancel Help

Function generator

Signal type

Constant
 Rectangle
 Sine
 Triangle
 Voltage profile

Edit profile...

Signal parameters

Frequency Hz (0..100)

Amplitude V (0..10)

y offset V (-10..10)

OK Cancel Help

